

**NOTES:**

1. ALL LATERAL STREET CUTS MUST BE COVERED WITH STEEL PLATES OF SUFFICIENT THICKNESS TO SPAN THE CUT WITHOUT NOTICEABLE DEFLECTION. PLATES TO REMAIN IN PLACE UNTIL THE CONCRETE BASE HAS GAINED SUFFICIENT STRENGTH TO WITHSTAND TRAFFIC LOADS (24 HOUR MINIMUM).
2. ON LONGITUDINAL CUTS EXCEEDING 150 FEET IN LENGTH, THE CONCRETE IN THE TRENCH WILL BE BROUGHT FLUSH WITH THE EXISTING PAVEMENT AND THE ENTIRE WIDTH OF THE ROADWAY RESURFACED WITH ASPHALT TOPPING COURSE AS DIRECTED BY THE JACKSON COUNTY ENGINEER.

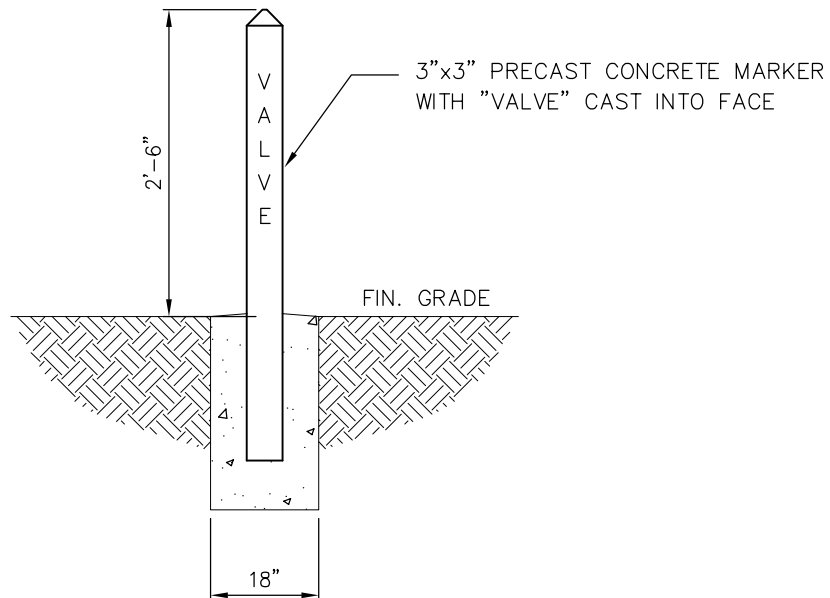

**JCWSA STANDARD DETAIL C-20  
PAVEMENT PATCH AND VALVE MARKER**

**SCALE: NTS  
DATE OF LAST REVISION: 12/06**

**JACKSON COUNTY  
WATER & SEWERAGE AUTHORITY**

